

TAPER BUCHSEN / ZÖLLIG

Type A

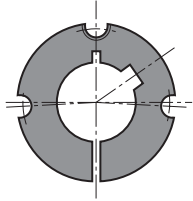

Type B

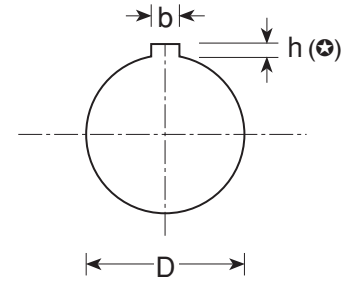
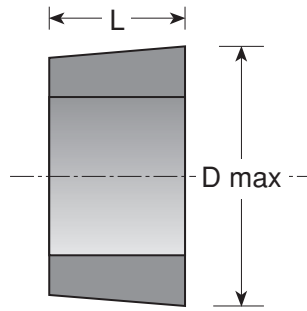
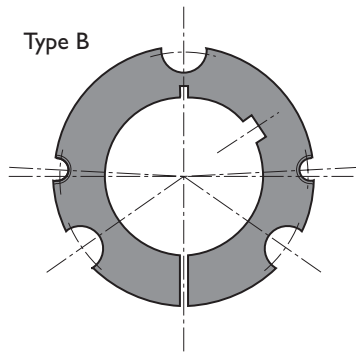

Ø D Zoll F 8	B Zoll H 9	H (⊕) Zoll	1008	1108	1210	1215	1310	1610	1615	2012	2017	2517	2525	3020	3030	3525	3535	4030	4040	4535	4545	5040	5050	
3/8	1/8	1/16	●	●																				
7/16	1/8	1/16	●	●																				
1/2	1/8	1/16	●	●	●	●	●	●	●															
9/16	3/16	3/32	●	●	●	●	●	●	●															
5/8	3/16	3/32	●	●	●	●	●	●	●															
11/16	3/16	3/32	●	●	●	●	●	●	●															
3/4	3/16	3/32	●	●	●	●	●	●	●	●	●	●												
13/16	1/4	1/8	●	●	●	●	●	●	●	●	●	●	●											
7/8	1/4	1/8	●	●	●	●	●	●	●	●	●	●	●	●										
15/16	1/4	1/8 (1/16)	★	●	●	●	●	●	●	●	●	●	●	●										
1	1/4	1/8 (1/16)	★	●	●	●	●	●	●	●	●	●	●	●										
1 1/16	5/16	1/8 (5/64)		★	●	●	●	●	●	●	●	●	●	●										
1 1/8	5/16	1/8 (5/64)		★	●	●	●	●	●	●	●	●	●	●										
1 3/16	5/16	1/8			●	●	●	●	●	●	●	●	●	●										
1 1/4	5/16	1/8			●	●	●	●	●	●	●	●	●	●	●	●								
1 5/16	3/8	1/8					●	●	●	●	●	●	●	●	●	●								
1 3/8	3/8	1/8					●	●	●	●	●	●	●	●	●	●								
1 7/16	3/8	1/8						●	●	●	●	●	●	●	●	●								
1 1/2	3/8	1/8						●	●	●	●	●	●	●	●	●	●							
1 5/8	7/16	5/32 (1/8)						●	★	●	●	●	●	●	●	●	●	●						
1 3/4	7/16	5/32								●	●	●	●	●	●	●	●	●	●	●	●	●	●	●
1 7/8	1/2	5/32								●	●	●	●	●	●	●	●	●	●	●	●	●	●	●
2	1/2	5/32								●	●	●	●	●	●	●	●	●	●	●	●	●	●	●
2 1/8	5/8	7/32										●	●	●	●	●	●	●	●	●	●	●	●	●
2 1/4	5/8	7/32										●	●	●	●	●	●	●	●	●	●	●	●	●
2 3/8	5/8	7/32										●	●	●	●	●	●	●	●	●	●	●	●	●
2 1/2	5/8	7/32										●	●	●	●	●	●	●	●	●	●	●	●	●
2 5/8	3/4	1/4												●	●	●	●	●	●	●	●	●	●	●
2 3/4	3/4	1/4												●	●	●	●	●	●	●	●	●	●	●
2 7/8	3/4	1/4												●	●	●	●	●	●	●	●	●	●	●
3	3/4	1/4												●	●	●	●	●	●	●	●	●	●	●
3 1/8	7/8	5/16														●	●	●	●	●	●	●	●	●
3 1/4	7/8	5/16														●	●	●	●	●	●	●	●	●
3 3/8	7/8	5/16														●	●	●	●	●	●	●	●	●
3 1/2	7/8	5/16 (1/4)														★	★	●	●	●	●	●	●	●
3 3/4	1	3/8 (1/4)															★	★	●	●	●	●	●	●
4	1	3/8 (1/4)															★	★	●	●	●	●	●	●
4 1/4	1 1/4	7/16 (1/4)																★	★	●	●	●	●	●
4 1/2	1 1/4	7/16 (1/4)																	★	★	●	●	●	●
4 3/4	1 1/4	7/16																		★	★	●	●	●
5	1 1/4	7/16 (5/16)																				★	★	●